

# PowerKit Engine 12M26 Series

## General Specifications

Bore x Stroke	150 x 150 mm
Displacement	31.8 L
N° of Cylinders	12
Cylinders Arrangement	At Vee
Fuel System	Mechanical Pump
Governor (Gov.)	Electronic
Aspiration (Asp.)	T/A-A

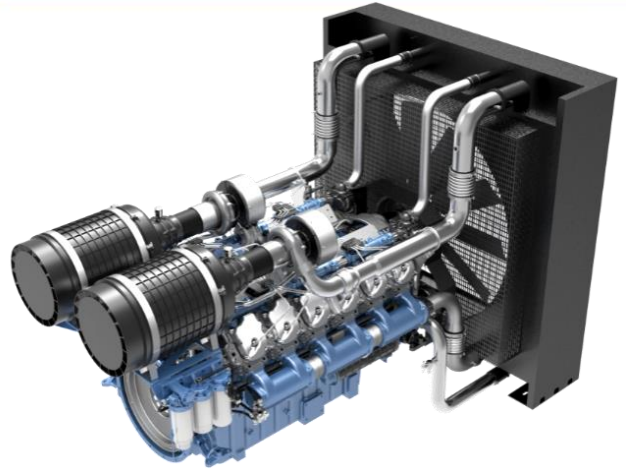

Diesel Engine		Gross Engine Output		Typical Generator Output				Asp.	Gov.
Model	Speed Rpm	Prime Power PRP kWm	Standby Power ESP kWm	Prime Power (PRP)		Standby Power (ESP)			
				kWe	kVA	kWe	kVA		
12M26G825/5	1500	683	748	600	750	660	825	T/A-A	Elec
12M26G900/5	1500	725	793	652	815	720	900	T/A-A	Elec
12M26G1000/5	1500	820	902	720	900	800	1000	T/A-A	Elec
12M26G1100/5	1500	889	973	816	1020	898	1120	T/A-A	Elec
12M26G660/6	1800	680	748	600	750	660	825	T/A-A	Elec
12M26G704/6	1800	720	792	640	800	704	880	T/A-A	Elec
12M26G800/6	1800	820	902	720	900	800	1000	T/A-A	Elec
12M26G900/6	1800	920	1012	800	1000	900	1125	T/A-A	Elec
12M26G1000/6 <sup>^</sup>	1800	1014	1115	910	1138	1000	1250	T/A-A	Elec

Aspiration : T/A-A = Turbocharged & Air-to-Air Aftercooled

<sup>^</sup> These engines are designed for emergency standby power (ESP) applications only. The indicated PRP Power is for reference only.

## Standard Equipment

### Engine and block

Cast iron cylinder block with inspection door per cylinder  
 Cast iron cylinder liners, wet type and replaceable valves guides and seats  
 Separate cast iron cylinder heads with 4 valves  
 Hardened steel forged crankshaft with induction hardened journals, crankpins and radius  
 Lube oil cooled light alloy pistons with high performance piston rings

### Cooling system

Radiator and hoses supplied separately  
 Thermostatically-controlled system with belt driven coolant pump and pusher fan

### Lubrication system

Full flow screw able oil filters  
 Lube oil purifier with replaceable cartridge  
 Water cooled lube oil cooler

### Fuel system

In line fuel injection pump with flanged electronic governor  
 Duplex fine filter and water separation filter assembly with transparent cup for better efficiency  
 Electric fuel priming pump integrated in the filters support

### Air intake and exhaust system

Top mounted turbocharger optimized for genset application  
 Special rear mounted air filter with restriction indicator  
 Exhaust manifold and turbocharger shield for heat isolating

### Electrical system

24 Vdc electric starter motor and battery charging alternator  
 LOP + HWT sensors

### Flywheel and housing

SAE 0 flywheel housing and 18" flywheel

# PowerKit Engine 12M26 Series

## Dimensions and Weight

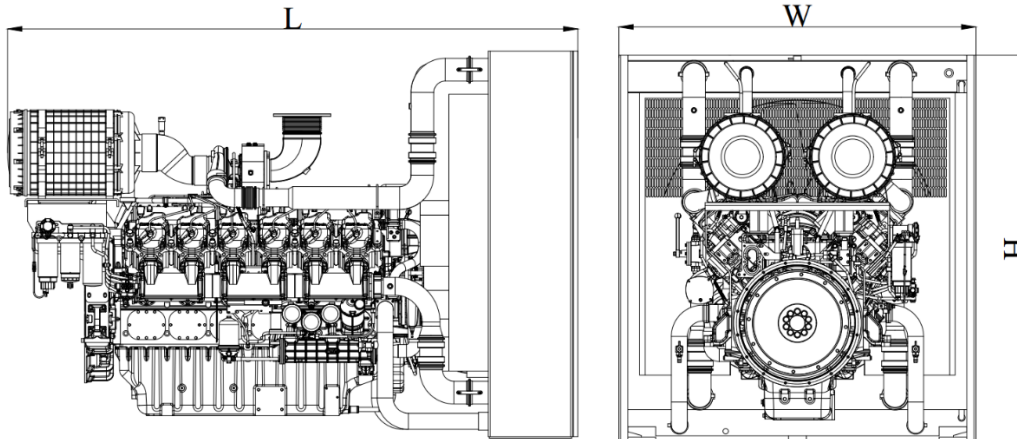

Diesel Engine		Dimensions and dry weights including radiator			
Model	Speed Rpm	L mm	W mm	H mm	Weight Kg.
12M26G825/5	1500	3182	1992	2150	3660
12M26G900/5	1500	3182	1992	2150	3660
12M26G1000/5	1500	3182	1992	2150	3660
12M26G1100/5	1500	3182	1992	2150	3660
12M26G660/6	1800	3182	1992	2150	3660
12M26G704/6	1800	3182	1992	2150	3660
12M26G800/6	1800	3182	1992	2150	3660
12M26G900/6	1800	3182	1992	2150	3660
12M26G1000/6	1800	3153	2026	2150	3700

## Ratings definitions

### Emergency Standby Power (ESP)

Emergency Standby Power is the maximum power available for a varying load for the duration of a main power network failure. The average load factor over 24 hours of operation should not exceed 70% of the engine's ESP power rating. Typical operational hours of the engine is 200 hours per year, with a maximum usage of 500 hours per year. This includes an annual maximum of 25 hours per year at the ESP power rating. No overload capability is allowed. The engine is not to be used for sustained utility paralleling applications.

### Unlimited Prime Rated Power (PRP)

Prime Power is the maximum power available for unlimited hours of usage in a variable load application. The average load factor should not exceed 70% of the engine's PRP power rating during any 24 hour period. An overload capability of 10% is available, however, this is limited to 1 hour within every 12 hour period.

### Continuous Power (COP)

Continuous Power is the maximum power available for an unlimited period of use at a constant load factor. No overload capability is allowed.

- 1) All ratings are based on operating conditions under ISO 8528-1, ISO 3046, DIN6271. Performance tolerance of  $\pm 5\%$ .
- 2) Test conditions : 100 kPa, 25°C air inlet temperature, relative humidity of 30%, with fuel density 0.84 kg/L. Derating may be required for conditions outside these; please contact the factory for details.
- 3) Power output curves are based on the engine operating with fuel system, water pump and lubricating oil pump; not included are battery charging alternator, fan and optional equipment.